



Effects of flexor-pronator muscle loading on valgus stability of the elbow with an intact, stretched, and resected medial ulnar collateral ligament

John H. Udall, MD, Michael J. Fitzpatrick, MD, Michelle H. McGarry, MS, Thu-Ba Leba, MD, Thay Q. Lee, PhD*

Orthopaedic Biomechanics Laboratory, Long Beach VA Healthcare System, Mission Regional Medical Center, and University of California, Irvine, CA

Background: The medial ulnar collateral ligament (MUCL) is an important passive stabilizer to the valgus stresses that athletes experience during overhead throwing motion. However, the role of the flexor-pronator muscles as active stabilizers to valgus stress is not well defined in the literature. The objectives of this study were to quantify the relative contribution of the individual flexor-pronator muscles to valgus stability of the elbow and how this relationship was affected by ligament status.

Methods: A custom elbow testing system and Microscribe 3DLX were used for biomechanical testing. Flexor-pronator muscles were loaded to simulate contraction, and the valgus angle of the elbow was measured in eight cadaveric specimens at 30°, 60°, and 90° of elbow flexion with 3 different valgus torques applied to the forearm. Loads based on muscle cross-sectional area were applied to the flexor carpi ulnaris (FCU), flexor digitorum superficialis (FDS), and pronator teres (PT). The effect of each muscle was evaluated by unloading the individual muscle while the other 2 remained loaded, resulting in 5 loading conditions: no muscles loaded, all muscles loaded, unloaded FCU, unloaded FDS, and unloaded PT. Valgus angle was measured for 3 MUCL ligament conditions: intact, stretched, and cut.

Results: The effect of muscle loading on valgus angle was similar for each ligament condition. Loading the flexor-pronator muscles significantly decreased valgus angle of the elbow in all testing conditions ($P < .01$). Unloading the FDS significantly increased valgus angle compared to all muscles loaded in all testing conditions ($P < .016$). Unloading the FCU and PT significantly increased valgus angle in less than half of the testing conditions.

Conclusion: The FDS, PT, and FCU are all active stabilizers of the elbow to valgus stress. The FDS is the biggest contributor amongst the flexor-pronator muscles.

Level of evidence: Basic science biomechanical laboratory study.

© 2009 Journal of Shoulder and Elbow Surgery Board of Trustees.

Keywords: Elbow; ulnar collateral ligament; overhead throwing; valgus stability; valgus stress; flexor-pronator muscles; biomechanical testing

*Reprint requests: Thay Q Lee, PhD, Orthopaedic Biomechanics Laboratory, VA Long Beach Healthcare System (09/151) 5901 East 7th Street, Long Beach, CA 90822

E-mail addresses: tqlee@med.va.gov, tqlee@uci.edu (T.Q. Lee).

The medial ulnar collateral ligament (MUCL) is the primary stabilizer to valgus stresses in the elbow.^{13,22} In overhead throwing athletes, a tremendous valgus force is produced at the elbow. Professional pitchers generate up to 120 Nm of valgus torque about the elbow.⁹ In cadaveric

studies, the ultimate failure of the MUCL averages 34 Nm.¹ The difference between the valgus forces generated at the elbow and the ultimate strength of the MUCL must then be resisted by other stabilizers. These stabilizers include the passive constraints of the joint capsule, radio-capitellar and ulnohumeral articulations, and the active constraints of the flexor-pronator muscles.¹⁴ A number of studies have demonstrated that the flexor-pronator muscles are the primary active stabilizers to valgus stress at the elbow.^{3,6}

Controversy still remains in the literature as to which muscle of the flexor-pronator mass contributes most significantly to the elbow's active stability. Davidson et al⁶ provided evidence that the flexor carpi ulnaris (FCU) and flexor digitorum superficialis (FDS) were likely the main contributors to active stability of the elbow. These authors hypothesized that the FCU and FDS were the biggest active constraints to valgus stress due to the FCU's optimal position overlying the MUCL, and the relatively large size of the FDS. A cadaveric study by Park et al¹⁶ showed that the FCU was the greatest contributor to valgus stability of the flexor-pronator muscles. An et al³ investigated the potential torques of muscles across the elbow by multiplying the moment arm of each muscle by its physiological cross-sectional area. These authors calculated that for most elbow positions of flexion, extension, and forearm rotation, the FDS provided the greatest varus moment arm of the flexor-pronator muscles.

Elbow instability has been extensively studied using cadaver models^{4,14,17,21,22}; however, these studies have sectioned the MUCL to simulate injury. Often injuries to the MUCL are due to chronic overload, leading to progressive and partial failure of the ligament.^{23,24} Sectioning studies produce large increases in valgus instability of the elbow that are not clinically seen in patients with MUCL injuries. In biomechanical studies of the shoulder, a number of authors have noted the limitations of sectioning studies as a means of simulating injuries of the capsuloligamentous structures about the shoulder.^{8,10,18} In this study, we introduce a novel method of simulating valgus instability of the elbow.

In our study, we have 2 hypotheses. The first is that the FDS produces the largest active correction to valgus instability in MUCL deficient elbows. The second hypothesis is that a stretching model can produce valgus laxity in the elbow that may more closely simulate the injury pattern seen in the throwing athlete.

The first objective of this study was to determine which of the flexor-pronator muscles contributed most significantly to valgus stability, taking into consideration the muscles' differing force-producing potentials, as well as their unique anatomic positions about the elbow and forearm. The second objective was to compare quantitatively the effects of the flexor-pronator muscles on valgus stability under 3 conditions of the MUCL ligament: intact, stretched, and cut.

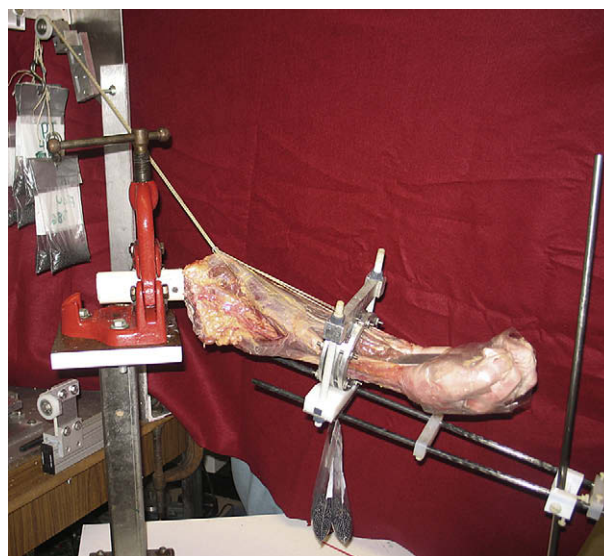

Figure 1 Photograph of the custom elbow testing system used to measure valgus angle of the elbow under varying degrees of elbow flexion and valgus loading of the elbow with or without pronator muscle loading.

Methods

Specimen preparation and testing set-up

Eight cadaveric elbows were used in the study: 4 left and 4 right. The age at death of the specimens ranged from 61 to 89 years with an average age of 74.5 years. The specimens consisted of the distal one third of the humerus and the entire forearm, wrist, and hand. The specimens were stored at -70°C and thawed overnight at room temperature. The skin and subcutaneous tissues were removed, leaving the muscles, joint capsule, and MUCL intact. All specimens were kept moist throughout preparation and testing with normal saline. The humerus was potted rigidly in PVC pipe with plaster-of-Paris and screws. Dacron line was sutured to the tendons of the PT, FDS, and FCU in a running, locked suture just distal to the musculotendinous junction. The line was then passed through an eyelet at the medial epicondyle. The eyelet simulated the origin of the flexor-pronator muscles. A pulley system was developed to allow application of various loads to each of the muscles for testing. The elbow was mounted with the epicondylar axis perpendicular to the ground, with the medial epicondyle pointing up and the lateral epicondyle pointing down. A custom jig was mounted to the distal radius that controlled forearm rotation but allowed varus-valgus movement. A metal plate was secured to the distal radius and second metacarpal, thus spanning the wrist and preventing wrist flexion when the muscle tendons were loaded. The phalanges were also secured to prevent movement of the fingers with tendon loading (Figure 1).

Biomechanical testing

The relative loads of the muscles were based on the cross-sectional areas of the muscles.³ The FDS, FCU, and PT were loaded with 14.4 N, 7.6 N, and 8.0 N, respectively, totaling 30 N.

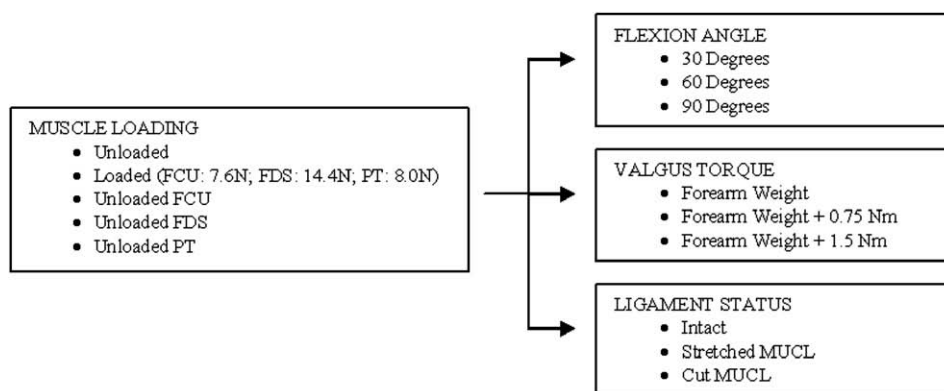

Figure 2 Diagram of the testing conditions listing all independent variables.

To evaluate the effect of each muscle on valgus laxity, the elbow was loaded with all of the muscles together and then sequentially with 2 of the 3 muscles loaded at a time. The order of muscle loading and unloading was randomized between specimens to eliminate bias of testing sequence. This method enabled us to look at the relative increase in valgus angle for each muscle as it was unloaded. The specimen was tested at 30°, 60°, and 90° of elbow flexion in neutral forearm rotation.²⁰ Before testing, the elbow was pre-conditioned by loading it cyclically with 3 Nm at each flexion angle. Prior to each individual testing condition, the elbow was preconditioned again to minimize creep.

The elbows were tested sequentially with an intact, stretched, and cut MUCL. For each of these ligament conditions and muscle load combinations, the valgus angle was measured after loading the elbow with each of the 3 following torques: the torque generated by the forearm and jig, the torque generated by the forearm and jig plus an additional 0.75 Nm, and the torque generated by the forearm and jig plus an additional 1.5 Nm.

After the elbow was tested with the intact MUCL for each of the muscle loading combinations and each of the applied loads at the various angles of elbow flexion, the MUCL was then stretched. The stretched ligament condition was achieved by applying a valgus torque until the valgus angle was 50% greater than the initial varus-valgus angle. The initial varus-valgus angle was defined by measuring the angle produced by a 3-Nm varus load and a 3-Nm valgus load applied to the elbow. Studies have shown that the anterior band of the MUCL's anterior bundle is stretched with elbow extension,⁵ whereas the posterior band is stretched with elbow flexion⁵; therefore, the stretching process was performed at 30° and 90° of elbow flexion. To reach the desired valgus angle for stretching, the torque was gradually increased until this angle was reached as verified by the Microscribe. This position was then maintained for 45 minutes in 30° of elbow flexion. This process was then repeated for 90° of elbow flexion for a total of 90 minutes of stretching time. This increase in valgus angle required an average torque of 5.5 Nm (range, 3.8-7.5 Nm). This torque is lower than load to failure values of the MUCL which have been reported to be between 14 and 34 Nm.^{1, 15} After the MUCL was stretched, testing was then performed for each of the conditions as outlined above.

After the testing had been performed with the intact and stretched ligament, the MUCL was transected mid-ligament. The elbow was tested in the cut condition as it had been in the intact and stretched conditions. In this manner, we were able to look at changes in valgus angle of the elbow with respect to muscle loading in the intact, stretched, and cut MUCL conditions.

In total, for each elbow tested, there were 5 different combinations of muscle loading representing muscle contraction (unloaded, loaded with 30 N, and unloading of the FCU, PT, and FDS); 3 different valgus loads applied to the elbow (weight of the forearm, weight of the forearm plus 0.75 Nm, and weight of the forearm plus 1.5 Nm); 3 different ligament conditions (intact, stretched, and cut), and 3 different flexion angles of the elbow (30°, 60°, and 90° of elbow flexion). Therefore, there were a total of 27 conditions for each of the 5 muscle loading combinations as described above (Figure 2). A Microscribe 3DLX (Immersion Corp, San Jose, CA) was used to measure the valgus angle of the elbow for each of the testing conditions.² The accuracy and repeatability of the valgus angle measurement was determined to be 0.2° and 0.1°, respectively. A 4-factor repeated measures analysis of variance for the factors of ligament condition, elbow flexion, valgus torque, and muscle loading was performed with a significance level of 0.05 using Statistica software (StatSoft, Tulsa, OK). If significant differences were determined a Tukey post hoc test was performed to compare across the different levels of the repeated measures.

Results

The average valgus angles for all conditions and positions are shown in Table I. There was no significant difference in the valgus angle with flexion angle of the elbow for any ligament condition or torque applied ($P > .06$). The valgus angle significantly increased with an increase in applied torque ($P < .05$). Stretching the MUCL significantly increased the valgus angle an average of $1.4 \pm 0.4^\circ$ compared to the intact MUCL across all conditions ($P = .01$). Cutting the MUCL also significantly increased the valgus angle an average across all conditions of $7.6 \pm 1.8^\circ$ from the stretched condition ($P = .004$).

The effect of muscle loading on the valgus angle was similar for each torque applied and for all MUCL conditions (intact, stretched, or cut). Loading the flexor-pronator muscles significantly decreased the valgus angle for all 27 conditions ($P < .005$) an average of $1.8 \pm 0.4^\circ$ for the cut MUCL condition across all flexion angles and torques applied. Unloading the FDS compared to the condition in which all muscles were loaded significantly increased the

Table I Average valgus angle in degrees for each testing condition, standard error ranged from 0.9° to 2.6°

	INTACT MUCL					STRETCHED MUCL					CUT MUCL				
FOREARM WEIGHT VALGUS TORQUE															
ELBOW FLEXION	UN	LD	UN	UN	UN	UN	LD	UN	UN	UN	UN	LD	UN	UN	UN
			FCU	FDS	PT			FCU	FDS	PT			FCU	FDS	PT
30°	8.4	6.9	7.6	7.9	7.5	10.1	8.1	8.8	9.3	8.9	14.5	11.7	12.9	13.5	13.1
60°	7.9	6.7	7.0	7.3	7.1	9.5	8.0	8.3	8.6	8.2	15.4	13.4	14.4	14.6	14.3
90°	6.7	5.5	5.8	6.1	5.8	8.7	6.8	7.1	7.4	7.0	14.5	12.6	13.5	13.9	13.3
FOREARM WEIGHT PLUS 0.75 Nm VALGUS TORQUE															
ELBOW FLEXION	UN	LD	UN	UN	UN	UN	LD	UN	UN	UN	UN	LD	UN	UN	UN
			FCU	FDS	PT			FCU	FDS	PT			FCU	FDS	PT
30°	8.7	7.6	8.1	8.3	8.0	10.2	9.0	9.3	9.7	9.4	16.7	14.8	15.9	16.5	16.1
60°	8.3	7.2	7.5	7.7	7.5	9.8	8.5	8.7	9.1	8.7	18.2	16.4	17.2	17.5	17.2
90°	7.1	6.1	6.3	6.5	6.2	8.9	7.3	7.5	7.8	7.5	16.9	15.1	16.0	16.4	15.9
FOREARM WEIGHT PLUS 1.5 Nm VALGUS TORQUE															
ELBOW FLEXION	UN	LD	UN	UN	UN	UN	LD	UN	UN	UN	UN	LD	UN	UN	UN
			FCU	FDS	PT			FCU	FDS	PT			FCU	FDS	PT
30°	9.1	8.1	8.5	8.8	8.5	10.6	9.4	9.7	10.1	9.8	18.8	17.9	18.7	19.0	18.6
60°	8.6	7.7	7.9	8.2	7.9	10.2	8.9	9.1	9.4	9.2	20.4	19.2	20.0	20.3	20.0
90°	7.5	6.4	6.7	6.9	6.6	9.2	7.7	8.0	8.3	8.0	19.1	17.6	18.4	18.7	18.2

UN, unloaded; LD, loaded, UN FCU, unloaded flexor carpi ulnaris; UN FDS, unloaded flexor digitorum superficialis; UN PT, unloaded pronator teres.

valgus angle in all 27 conditions ($P < .016$). For the cut MUCL, there was an average increase in the valgus angle when unloading the FDS of $1.3 \pm 0.2^\circ$. When unloading the FCU, there was a smaller increase in the valgus angle, an average of $0.9 \pm 0.2^\circ$ for the cut MUCL, and was only significant for 12 of the 27 conditions. When unloading the PT, a similar increase in the valgus angle was seen as when unloading the FCU, which was a significant increase in only 10 of the 27 conditions. There was no significant difference between the valgus angle when comparing the FCU unloaded condition to the PT unloaded condition ($P > .6$). A representative graph of the effect of muscle loading on the valgus angle is shown for the forearm weight condition and 60° of elbow flexion (Figure 3).

Discussion

The literature is unclear as to which flexor-pronator muscle plays the greatest role as an active stabilizer to valgus stresses at the elbow. The findings of this study support our hypothesis that the FDS is the greatest contributor to valgus stability of the elbow. Although the arm and forearm musculature are not large contributors to force generation during throwing motion, they play important roles in the accuracy and control in overhead throwing athletes.¹² The flexor-pronator muscles also play a role in the stability of the elbow joint to valgus stress, but this role is not as well defined and more controversial, particularly in the elbow with a MUCL injury. Some fibers of the flexors are intimately attached to the MUCL; therefore, injury to the MUCL could potentially cause concomitant damage to the overlying musculature.⁶ Many injuries to the MUCL are secondary to improper throwing mechanics, training, and

muscle fatigue. As the muscles about the forearm fatigue, the ligamentous and bony structures undergo a greater load, which can ultimately cause ligamentous failure of the MUCL and bony changes in the posteromedial olecranon and radiocapitellar joint.

Park et al¹⁶ showed that the FCU is the biggest contributor to valgus stability in MUCL deficient elbow. In their study, the FCU, FDS, and PT were all loaded equally with 15 N. With these equal loads, the FCU gave the greatest correction to valgus angulation compared to either the FDS or PT. They hypothesized that the FCU has a more advantageous position to provide stability to valgus stress. Davidson et al⁶ also showed that the FCU was overlying the MUCL more than the other flexor-pronator muscles. It was shown that the FCU was consistently overlying the MUCL at 30° , 90° , and 120° , whereas the PT and FCR were never overlying the MUCL at these positions of elbow flexion. The FDS was overlying the MUCL at 30° of elbow flexion, and less so at 90° and 120° . Although the FDS did not have as optimal a position as the FCU, it had a relatively greater bulk and, therefore, greater force-producing potential than the other flexor-pronator muscles. They reasoned that the FCU because of its optimal position and the FDS because of its relative bulk were the biggest active stabilizers of the elbow to valgus stress. In our cadaveric model, the angular difference in the line of pull of the FDS versus the FCU was not very large. The insertion of the FCU on the pisiform is only a few centimeters from the tendons of the FDS, which travel through the carpal tunnel radial to the FCU. Therefore, the relative line of pull of the FCU and FDS are very similar, even though the FCU is more consistently positioned over the MUCL.

An et al³ calculated the various moment arms of the flexor-pronator muscles in different positions of flexion and extension, and with different positions of forearm rotation.

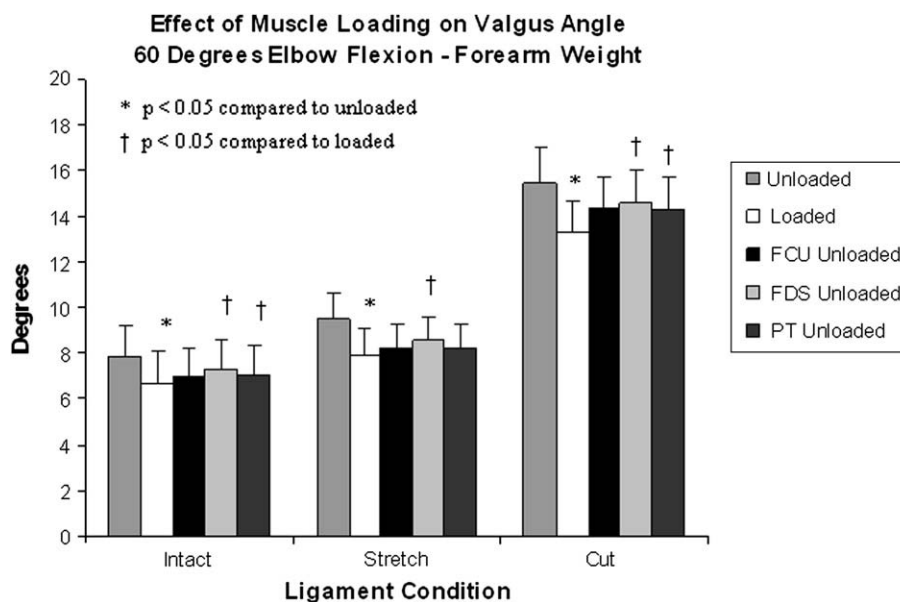

Figure 3 Effect of flexor-pronator muscle loading on valgus angle measured at 60° of elbow flexion for the forearm weight torque condition and each ligament status of intact, stretched, and cut.

They calculated that the moment arm of the FDS was slightly greater than that of the FCU in extension (2.095 cm vs 1.419 cm, respectively) as well as in flexion (1.887 cm vs 1.611 cm). They also calculated the potential moment contribution of each of the muscles crossing the elbow joint by multiplying their cross-sectional area, representing the force-producing potential, by their lever arm across the elbow joint. These investigators calculated that when the elbow was in the extended position with neutral forearm rotation, the potential moment contribution to flexion-extension and varus-valgus rotation of the FDS, FCU, and PT were 12.9, 7.1, and 5.7 cm x cm², respectively. In the flexed elbow with neutral forearm rotation, these investigators calculated the potential moment contribution to flexion-extension and varus-valgus rotation of the FDS, FCU, and PT to be 11.6, 6.6, and 7.6 cm x cm², respectively.³ In both positions of elbow flexion and extension with the forearm in neutral rotation, the FDS provides more potential varus moment contribution than the PT or the FCU, which also contribute to flexion and extension moments, respectively. The findings from their study suggest that the FDS provides greater stability to valgus stress than either the FCU or PT. While the findings from our study agree with Davidson et al,⁶ that the FCU's fibers are situated over the MUCL more so than those of the FDS, this advantage may be offset by the greater force-producing potential of the FDS and to a lesser degree by the slightly larger lever arm the FDS has compared to the FCU.

The results from the current study likely differ from other studies due to different methods of testing. Other studies have used equal loads in testing the FDS, FCU, and PT to determine which had the greatest contribution.¹⁶ In our study, the FDS was loaded with more weight than the FCU and PT based on its physiological cross-sectional area.

Another difference may be due to the line of pull of the respective muscles tested. In this study, a Dacron line was sutured directly into the muscle tendon to recreate the muscle insertion versus estimating the insertion site on a PVC pipe. Other studies have loaded the brachialis and triceps, which have a compressive effect at the elbow. These muscles were not simulated with loads in our test because, despite the fact that they do have a stabilizing effect on the elbow joint, and therefore on valgus stability, they should not affect the relationship between the valgus stabilizing muscles of the flexor-pronator mass.

Multiple cadaveric studies have simulated MUCL insufficiency by sectioning either part or all of the ligament.^{4,7,14,17,21,22} Within the anterior bundle of the MUCL, the main stabilizer against valgus stress, there are anterior and posterior bands. Due to the cam effect of the elbow, the anterior band tightens in extension while the posterior band tightens with increasing degrees of flexion.⁵ Sectioning studies in the past have targeted either the anterior or posterior bands to simulate partial tears, or the entire ligament to simulate full tears. Sectioning studies create large increases in valgus angulation of the forearm and are, therefore, inherently unable to accurately reproduce the injury patterns seen in clinical situations. Injury to the MUCL causes small changes in valgus angle of the elbow and opening of the ulnohumeral joint.¹⁹

Previous biomechanical stretching models of the shoulder have been developed to more closely simulate injury patterns seen in athletes.^{8,10,18} We believe that a stretching model of the elbow more accurately reproduces MUCL injury than sectioning studies. The difference in valgus angle of the elbow in our stretching and intact models was relatively small. This type of change is more representative of the changes seen in a clinical scenario. In our preliminary study,

there were differences in the pattern of radiocapitellar pressures between the cut and stretched models of the elbow. Further testing will need to be done to delineate the differences between the stretch and cut models of the MUCL.

One of the limitations of this study is the age of the cadaveric specimens that were used. These cadaveric specimens can have very different properties than the elbow of a young muscular overhead athlete. During our testing, an eyelet ripped out of one of our elbows with muscle loading, while in another specimen the MUCL tore from its insertion during the stretching process. We were thus limited in the amount of weight that could be used to load the elbow and the amount of stretching that the MUCL could tolerate prior to failure. The overall valgus laxity of an older cadaver may be larger than that of a younger cadaver; however, the change in the valgus angle with muscle loading and different ligament conditions would be similar.

The mechanism of injury and the valgus stresses to the MUCL are difficult to reproduce in a cadaveric setting. It is also unclear how much the flexor-pronators contribute to valgus stability in the injured elbow. One might expect the valgus stabilizing muscles to compensate in an elbow with MUCL insufficiency, but electromyographic studies have shown that the flexor-pronator muscles may actually fire less in pitchers with an MUCL injury.¹¹ Whether this is one of the causes or one of the effects of MUCL deficiency is unclear. Therefore, rehabilitation of the flexor-pronator muscles may have a variable effect on valgus stability of elbows with pre-existing injury to the MUCL. It is reasonable to infer that in the MUCL intact elbow, strengthening of the flexor-pronators, particularly the FDS, may have a beneficial role in preventing MUCL injury.

Although difficulties arise in extrapolating how the flexor-pronator muscles contribute to valgus stability in the MUCL deficient elbow, the findings from this study suggest that the flexor digitorum superficialis is the major muscular contributor to valgus stability of the elbow.

Disclaimer

This study was supported in part by VA Rehab R&D, VA Medical Research, and the John C. Griswold Foundation.

References

- Ahmad CS, Lee TQ, ElAttrache NS. Biomechanical evaluation of a new ulnar collateral ligament reconstruction technique with interference screw fixation. *Am J Sports Med* 2003;31:332-7.
- Ahmad CS, Park MC, ElAttrache NS. Elbow medial ulnar collateral ligament insufficiency alters posteromedial olecranon contact. *Am J Sports Med* 2004;32:1607-12.
- An KN, Hui FC, Morrey BF, et al. Muscles across the elbow joint: a biomechanical analysis. *J Biomech* 1981;14:659-69.
- Armstrong AD, Dunning CE, Ferreira LM, et al. A biomechanical comparison of four reconstruction techniques for the medial collateral ligament-deficient elbow. *J Shoulder Elbow Surg* 2005;14:207-15.
- Callaway GH, Field LD, Deng XH, et al. Biomechanical evaluation of the medial collateral ligament of the elbow. *J Bone Joint Surg Am* 1997;79:1223-31.
- Davidson PA, Pink M, Perry J, et al. Functional anatomy of the flexor pronator muscle group in relation to the medial collateral ligament of the elbow. *Am J Sports Med* 1995;23:245-50.
- Field LD, Altchek DW. Evaluation of the arthroscopic valgus instability test of the elbow. *Am J Sports Med* 1996;24:177-81.
- Fitzpatrick MJ, Tibone JE, Grossman M, et al. Development of cadaveric models of a thrower's shoulder. *J Shoulder Elbow Surg* 2005;14:49S-57.
- Fleisig GS, Andrews JR, Dillman CJ, et al. Kinetics of baseball pitching with implications about injury mechanisms. *Am J Sports Med* 1995;23:233-9.
- Grossman MG, Tibone JE, McGarry MH, et al. A cadaveric model of the throwing shoulder: a possible etiology of superior labrum anterior-to-posterior lesions. *J Bone Joint Surg Am* 2005;87:824-31.
- Hamilton CD, Glousman RE, Jobe FW, et al. Dynamic stability of the elbow: electromyographic analysis of the flexor pronator group and the extensor group in pitchers with valgus instability. *J Shoulder Elbow Surg* 1996;5:347-54.
- Hirashima M, Kadota H, Sakurai S, et al. Sequential muscle activity and its functional role in the upper extremity and trunk during overarm throwing. *J Sports Sci* 2002;20:301-10.
- Morrey BF, An KN. Articular and ligamentous contributions to the stability of the elbow joint. *Am J Sports Med* 1983;11:315-9.
- Morrey BF, Tanaka S, An KN. Valgus stability of the elbow. A definition of primary and secondary constraints. *Clin Orthop Relat Res* 1991:187-95.
- Paletta GA Jr, Klepps SJ, Difelice GS, et al. Biomechanical evaluation of 2 techniques for ulnar collateral ligament reconstruction of the elbow. *Am J Sports Med* 2006;34:1599-603.
- Park MC, Ahmad CS. Dynamic contributions of the flexor-pronator mass to elbow valgus stability. *J Bone Joint Surg Am* 2004;86-A:2268-74.
- Pomianowski S, O'Driscoll SW, Neale PG, et al. The effect of forearm rotation on laxity and stability of the elbow. *Clin Biomech (Bristol, Avon)* 2001;16:401-7.
- Remia LF, Ravalin RV, Lemly KS, et al. Biomechanical evaluation of multidirectional glenohumeral instability and repair. *Clin Orthop Relat Res* 2003:225-36.
- Rijke AM, Goitz HT, McCue FC, et al. Stress radiography of the medial elbow ligaments. *Radiology* 1994;191:213-6.
- Safran MR, McGarry MH, Shin S, et al. Effects of elbow flexion and forearm rotation on valgus laxity of the elbow. *J Bone Joint Surg Am* 2005;87:2065-74.
- Seiber K, Gupta R, McGarry MH, et al. The role of the elbow musculature, forearm rotation, and elbow flexion in elbow stability: an in vitro study. *J Shoulder Elbow Surg* 2009;18:260-8.
- Sojbjerg JO, Ovesen J, Nielsen S. Experimental elbow instability after transection of the medial collateral ligament. *Clin Orthop Relat Res* 1987:186-90.
- Timmerman LA, Andrews JR. Undersurface tear of the ulnar collateral ligament in baseball players. A newly recognized lesion. *Am J Sports Med* 1994;22:33-6.
- Timmerman LA, Schwartz ML, Andrews JR. Preoperative evaluation of the ulnar collateral ligament by magnetic resonance imaging and computed tomography arthrography. Evaluation in 25 baseball players with surgical confirmation. *Am J Sports Med* 1994;22:26-31; discussion 32.